

Semi Automatic Tyre Changer with Swing Arm

MODEL - PTC-1037



- Semi Automatic Tyre Changer with swing arm, reliable and at the right price.
- Horizontal tool positioning by means of threaded hand wheel, single action level.
- Self-centering four jaw chuck and powerful bead breaker.
- The machine adopts the parkerising bead breaker cylinder having bead breaking power **2500Kg** to bead break the tyre from rim easily.
- The control pedal assembly has the step-move function which can stop the clamp at any position to clamp the rim conveniently.
- The machine equips the protective cover for clamps and mounting head as standard configuration to avoid damaging the rim.
- The clamp is made of special material, strong and durable
- Specially designed to last long even under unfavourable conditions
- Rim size 10"-24"

HIGHLIGHTS



Strong and durable made of special steel



Universal switch with 40A silvered contacts which are more robust and better life span

TECHNICAL SPECIFICATIONS

Max. wheel diameter	1250 mm
Maximum Rim width	3" - 13"
Rim Clamping from outside	12" - 22"
Rim Clamping from inside	14" - 25"
RPM	6.5 r/min
Electric motor	0.75Kw / 1.1 Kw
Mains supply (Single Phase Optional)	1 Ph. 220 V / 3 Ph. 380 V
Operating air pressure	8-10 bar
Dimensions LxDxH	850 x 1250 x 1888 mm
Net Weight	239 kg

DIMENSIONS

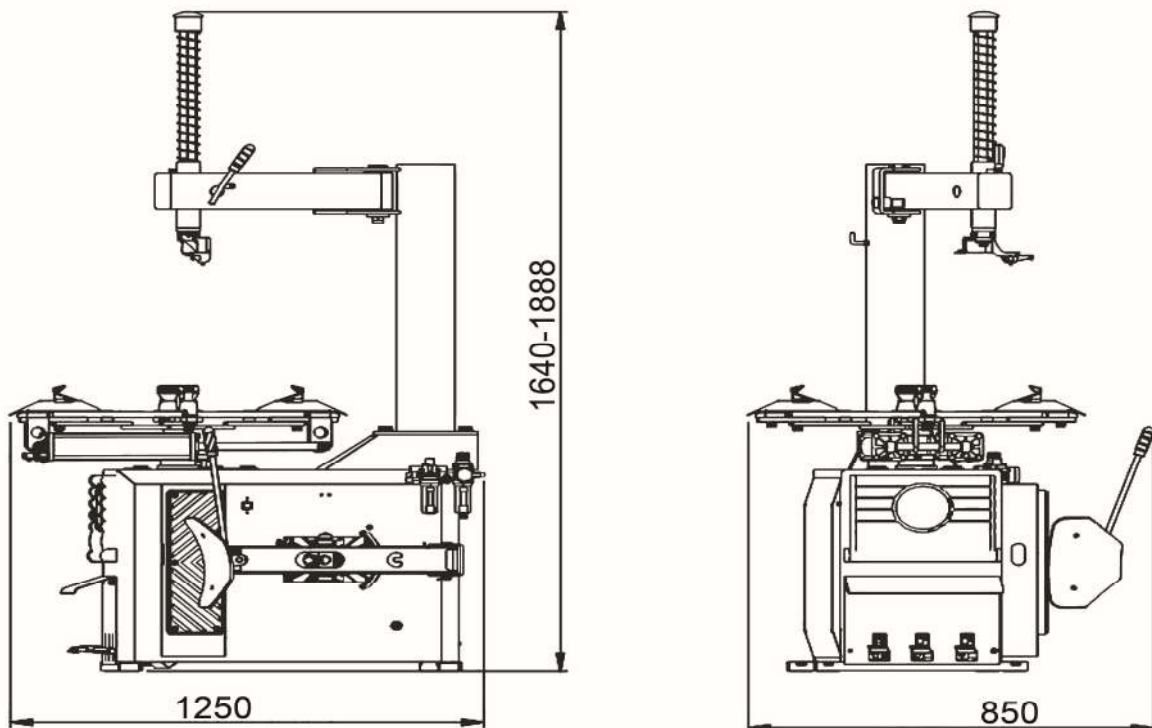

* Specifications subject to change without notice

* Images shown are for representation purpose only. Accessories & features shown in the picture may not be part of the standard equipment

PRECISION TESTING MACHINES PVT. LTD.

HEAD OFFICE: S-12, Okhla Industrial Area, Phase - II, New Delhi - 110 020 (India)

Tel.: 011-4161-0000 (4 lines), 2638-6612 Fax: 011-26383790

E-mail : sales@precisionworld.net / service@precisionworld.net / www.precisionworld.net

2



STORE TO BUY GENUINE **PRECISION** LIGHT EQUIPMENT & CONSUMABLES
Visit www.ptmeway.com