

**Automatic Tyre Changer  
with Tilting Pole**

MODEL - PTC-1048



- New Automatic Tyre Changer, the tilt backward and forward of the column and the lock of the column can be completed pneumatically.
- Self-centering four jaw chuck and powerful bead breaker.
- The machine adopts the parkerising bead breaker cylinder with Ø 200 diameter having bead breaking power **2800Kg** to bead break the tyre from rim easily.
- The control pedal assembly has the step-move function which can stop the clamp at any position to clamp the rim conveniently.
- The machine equips the protective cover for clamps and mounting head as standard configuration to avoid damaging the rim.
- The clamp is made of special material, strong and durable
- Turntable with outside adjustable jaws, which enlarge machine's mounting and dismounting range.
- The design of the bead breaker blade can rotate at any direction , securing the best bead breaking force. The bead breaker blade is equipped with the protective cover.
- The bead breaker arm has the 2 travels to ensure opetation max 15" tyre.
- Equiped with sturdy 41mm hexangular shaft and 50mm square shaft, avoids distortion while operation and more suitable for operation the flat and hard tyre.
- Specially designed to last long even under unfavourable conditions
- Rim size 10"-26": Good for large size rims

## HIGHLIGHTS



The clamp cylinder with  $\varnothing$  80 mm diameter increases the power to 106kg.



Sturdy bead breaker cylinder with  $\varnothing$ 200 diameter



The bead breaker arm has the 2 travel, which ensure to demount the maximum 15" tyre.



Strong and durable made of special steel



Highly reliable Universal switch with 40A silvered contacts which are more robust and better life span



## TECHNICAL SPECIFICATIONS

Max. wheel diameter	1100 mm
Maximum Wheel width	3" - 14"
Rim Clamping from outside	11" - 24"
Rim Clamping from inside	13" - 26"
Turntable Rotation Speed	6.5 - 13 rpm
Electric motor	0.75Kw / 1.1 Kw
Mains supply (Single Phase Optional)	1 Ph. 220 V / 3 Ph. 380 V
Operating air pressure	8-10 bar
Dimensions LxDxH	1600 x 1950 x 2150 mm
Net Weight	259 kg

## DIMENSIONS

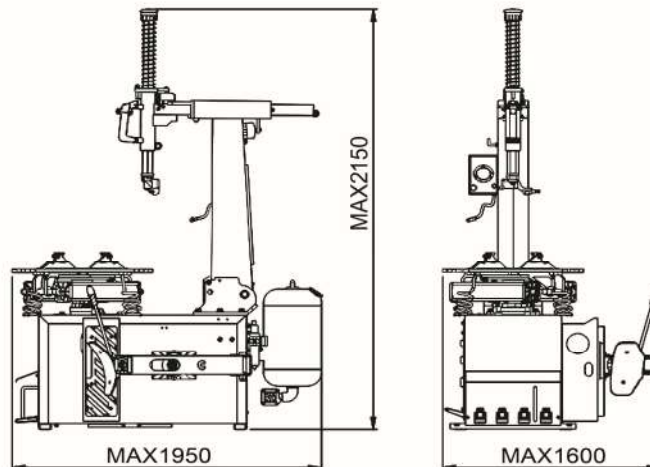

\* Specifications subject to change without notice

\* Images shown are for representation purpose only. Accessories & features shown in the picture may not be part of the standard equipment

## PRECISION TESTING MACHINES PVT. LTD.

HEAD OFFICE: S-12, Okhla Industrial Area, Phase - II, New Delhi - 110 020 (India)

Tel.: 011-4161-0000 (4 lines), 2638-6612 Fax: 011-26383790

E-mail : sales@precisionworld.net / service@precisionworld.net / [www.precisionworld.net](http://www.precisionworld.net)