

**INSPECTION HYDRAULIC  
SCISSORS LIFT IN GROUND**

MODEL - PXL-3600CG

**3.0T**



- 3.0 Ton lifting capacity..
- Underground installation, save place.
- The mechanical safety lock automatically engaged when lifting
- Pneumatic release system lower noise during operation
- Stable lifting, and Low noise.
- Electric/hydraulic power system.
- Double oil cylinder structure make levelling adjustment much easier
- Excellent design easy for car going on and out.
- Tested for 115% dynamic loading and 150% static loading test.

**APPLICATIONS**

- Ideal for Quick Repair Bays and Inspection bays, Wheels Free Double Scissor Lift zero level to ground and ensures higher productivity.
- Quick Under Chassis Inspection
- Wheel Changing
- Transmission System Inspection

**HIGHLIGHTS**



Double Safety Device - Mechanical Lock



Heavy Duty Structure with Smooth Scissors Movement

## TECHNICAL SPECIFICATIONS

Capacity	3000 Kg
Lifting Height	2100 mm
Minimum Height	320 mm
Lifting Time	35 Sec
Runway Length	1500 - 1750 mm
Overall Width of Platform	550 mm
Noise	≤ 75 dB (A)

## ELECTRIC SPECIFICATIONS

Electric Motor Power	2,2 Kw
Voltage	3ph. 220-380V trif. +/-5%
Frequency	50 Hz
Rated Oil Pressure	20 MPA
Air Supply	6-8 kg/cm <sup>3</sup>

## DIMENSIONS

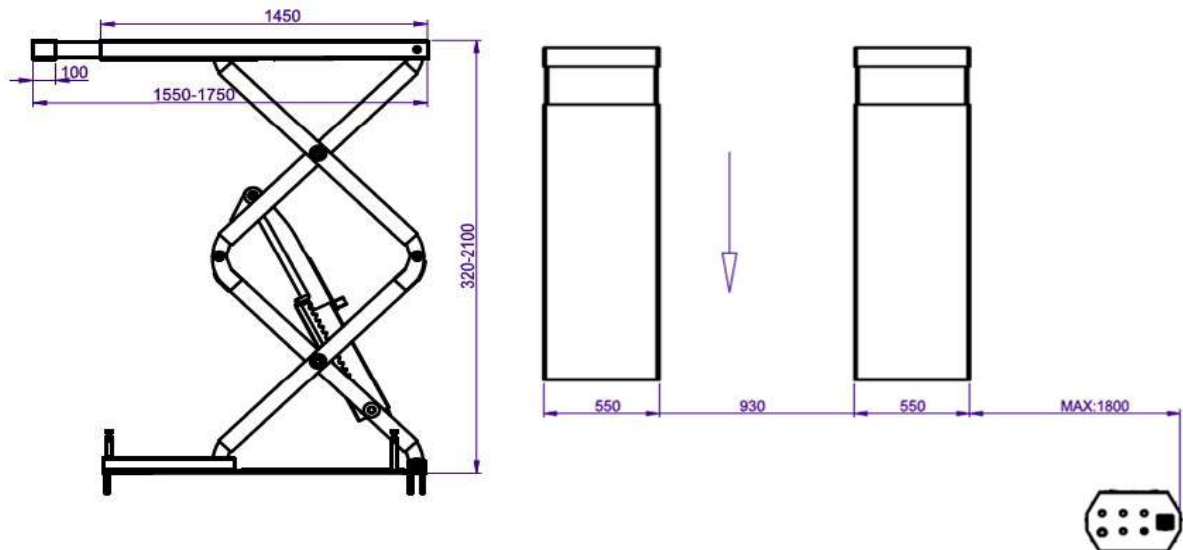

\* Specifications subject to change without notice

\*\* Images shown are for representation purpose only. Accessories & features shown in the picture may not be part of the standard equipment

## PRECISION TESTING MACHINES PVT. LTD.

HEAD OFFICE: S-12, Okhla Industrial Area, Phase - II, New Delhi - 110 020 (India)

Tel.: 011-4161-0000 (4 lines), 2638-6612 Fax: 011-26383790

E-mail : sales@precisionworld.net / service@precisionworld.net / [www.precisionworld.net](http://www.precisionworld.net)